

**PRESSURE  
TEST PUMP  
OPERATOR MANUAL**



## **CONTENTS**

---

<b>1.</b>	<b>INTRODUCTION</b> .....	<b>2</b>
1.1	Pressure Test Pump Kits .....	4
1.2	Release Valve .....	4
1.3	Volume Control.....	4
1.4	Over Pressure Protection .....	5
1.5	Pressure/Vacuum Selection .....	5
<b>2.</b>	<b>GUIDELINES FOR USE</b> .....	<b>6</b>
2.1	Calibration/Comparison against Comark Digital Pressure Meter.....	6
2.2	Use with High Resolution Pressure Ranges (1mBar) .....	8
2.3	Fault Investigation .....	8
<b>3.</b>	<b>PERFORMING HYSTERESIS TESTS</b> .....	<b>10</b>
3.1	Increasing Pressure.....	10
3.2	Decreasing Pressure to Measure Hysteresis .....	12
<b>4.</b>	<b>SPECIFICATION</b> .....	<b>13</b>

## **1. INTRODUCTION**

---

The pressure test pump is a dual portable source of either vacuum or pressure supply. Each pump incorporates a vacuum/pressure selector and a volume control feature for fine adjustment.



**WARNING**

**THE HAND PUMP IS CAPABLE OF GENERATING PRESSURES IN EXCESS OF 200 PSI. TO PREVENT DAMAGE IT IS ESSENTIAL NOT TO OVER PRESSURE ANY GAUGE CONNECTED TO THE PUMP.**

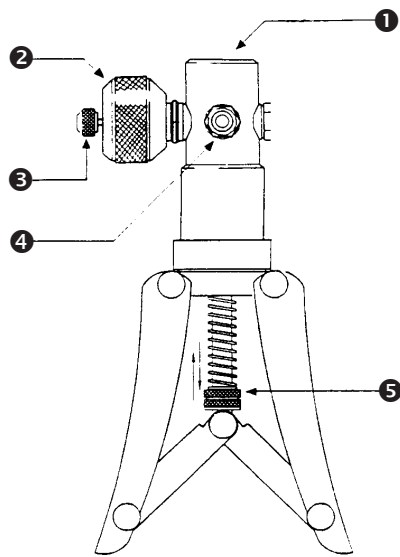

- ① Pressure port — 3/8" BSP Parallel female connection
- ② Fine adjustment valve
- ③ Pressure release valve
- ④ Pressure/vacuum selector
- ⑤ Adjustable stroke for varying maximum pressure output (over pressure protection)

### 1.1 Pressure Test Pump Kits

The TK1 kit can be used with the Kane-May KM5000 series and the TK2 kit with the C9500 series pressure meters and provides the capability to set up and check the calibration of pressure gauges, switches, pressure to current convertors and other pneumatic instruments.

**Note:** Do not overtighten the hexagonal nut when connecting the pressure meter tubing to the hand pump or the pressure pump could be damaged.

### 1.2 Release Valve ③

This can be used to reduce or release the pressure in the system. The rate of pressure reduction is dependent upon the degree of rotation when opening the valve. Minimal force is required to seal the system. **Excessive force may damage the internal seals.**

### 1.3 Volume Control ②

The pressure generated can be finely adjusted by turning the volume control valve either clockwise or anti-clockwise to increase or decrease pressure accordingly.

**IMPORTANT: Under no circumstances should the volume control valve ② be wound back beyond the red line indicator on the body. Should this occur, then the pressure must be released from the system before attempting to re-engage the volume control valve.**

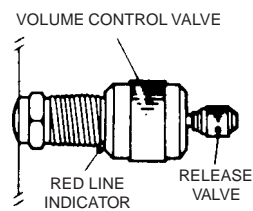

#### 1.4 Over Pressure Protection

To adjust the maximum output pressure of the system turn the nuts ⑤ to increase or decrease the stroke length.

#### 1.5 Pressure/Vacuum Selection ④

Press the selector ④ as indicated on the label to engage the desired mode. Ensure that the release valve ⑥ is fully closed (clockwise motion) prior to pumping.

#### Notes:

1. The pump should only be used for pressurising small volumes due to its small displacement.
2. If the pump has not been used for a period of time, it could be difficult to operate on the first stroke. This is due to the piston seal drying slightly.
3. The cylinder has been lightly greased on assembly but, if additional lubrication should ever be required, then apply a minimal amount to the inside of the cylinder. Access is via the three retaining screws located under the black collar.

For release valve seal replacement, please contact Comark Service Department or your Distributor.

## **2. GUIDELINES FOR USE**

---

### **2.1 Calibration/Comparison against Comark Digital Pressure Meter**

- (a) Fit KM5000 or C9500 instrument to test pump.
- (b) Connect gauge under test to pump choosing correct adaptors and seals from the set provided.

**Note:** Ensure both seals are fitted and adaptors are tightened. (See paragraph 1.1).

- (c) Screw volume control knob fully clockwise.
- (d) Screw pressure release valve fully clockwise, tightening to ensure good seal.
- (e) Screw volume control knob 4-6 full turns anti-clockwise.
- (f) Operate handles until the pressure is close to that finally required.



**WARNING**

**ONE FULL SQUEEZE OF THE HANDLES IS SUFFICIENT TO OVER RANGE A COMARK 2 PSI METER. IF THIS SHOULD OCCUR REDUCE THE PRESSURE UNTIL A READING SHOWS ON THE DISPLAY.**

- (g) Wind volume control knob clockwise to increase pressure or anti-clockwise to decrease pressure until required pressure is reached.

**Note:** The pressure may settle for up to 30 seconds after increasing pressure with pump due to thermodynamic effects, settling of seals and expansion of the flexible pipe.

**CAUTION: NEVER screw volume control knob anti-clockwise when red band is showing.**

- (h) Reductions in pressure can be achieved by careful use of the pressure release valve, however this valve is not guaranteed to seal fully unless the volume control knob is screwed fully clockwise.
- (i) Vacuum is achieved using procedure identified above and having the changeover valve pushed completely towards the vacuum position.

**Note:** The changeover valve should never be operated with the unit pressurised, only when the pressure release valve is open. Operation of this valve when unit is pressurised causes an instantaneous release of pressure which can damage the seals within the pump.

## **2.2 Use with High Resolution Pressure Ranges (1mBar)**

The higher resolution available will amplify the visibility of the thermodynamic effects as mentioned in paragraph 2.1(g). These should however still settle to useable values within one minute of pressurisation.

**Note:** On very high resolutions such as 1mBar or 0.1 inches of water, small movements of the pipe may result in noticeable pressure changes.

## **2.3 Fault Investigation**

In the event that the system appears to lose pressure then the procedure above should be repeated ensuring new seals are used, adaptors are tightened sufficiently and the pressure release valve is tightened firmly with the volume control knob screwed fully clockwise.

**Note:** The connections to the hand held test pump are sealed with nylon washers and should not leak. The pipe to body connection can be checked but tightened no more than 2Nm.

**DO NOT** attempt to tighten the other fittings to the test pump as this could lead to breaking of sealed joints.

When testing for leaks it may be noticed that air is drawn in or expelled from around the changeover valve. This is normal and should cause no concern.

Some instruments include pressure relief valves to protect the instrument. Before suspecting a leak in the pump check the relief valve pressure is not being exceeded and the relief valve is seated properly. This can be achieved by substitution with another gauge and retest for leaks.

### **3. PERFORMING HYSTERESIS TESTS**

The hand held test pump can be used with a high resolution instrument to check accuracy and hysteresis of a pressure measuring instrument.

#### **3.1 Increasing Pressure**

- (a) Fit KM5000 or C9500 instrument to test pump.
- (b) Connect the gauge under test to pump choosing correct adaptors and seals from the set provided.

**Note:** Ensure both seals are fitted and adaptors are tightened. (See paragraph 1.1).

- (c) Screw the volume control knob fully clockwise.
- (d) Screw the pressure release valve fully clockwise, tightening to ensure good seal.
- (e) Screw the volume control knob 8–9 full turns anti-clockwise.
- (f) Operate the handles until the pressure is slightly less than that finally required.



**WARNING**

**ONE FULL SQUEEZE OF THE HANDLES IS SUFFICIENT TO OVER RANGE A COMARK 2 PSI METER. IF THIS SHOULD OCCUR REDUCE THE PRESSURE UNTIL A READING SHOWS ON THE DISPLAY.**

- (g) Wind the volume control knob clockwise to increase pressure to the calibration point and record readings.

**Note:** The pressure may settle for up to 1 minute after increasing pressure with pump due to thermodynamic effects, settling of seals and expansion of the flexible pipe. If this is significant, operate the volume control knob again to retain calibration pressure.

**CAUTION: NEVER screw the volume control knob anti-clockwise when red band is showing.**

- (h) Repeat steps 3.1(f) and (g) for other calibration points. If the volume control knob does not have sufficient travel remaining, screw it fully clockwise and return to paragraph 3.1(e).
- (i) When maximum calibration pressure has been achieved and the results noted, proceed to paragraph 3.2 — Decreasing Pressure.

### **3.2 Decreasing Pressure to Measure Hysteresis**

To correctly measure hysteresis it is important that the pressure in the system never falls lower than the calibration point next required.

- (a) Carefully unscrew the release valve slightly to allow the pressure to drop gently, but not to fall below the next calibration point. Fully tighten the release valve (clockwise).
- (b) Screw the volume control knob fully clockwise, repeating paragraph 3.2(a) if maximum pressure is reached before volume control knob is fully screwed in.
- (c) Carefully unscrew the release valve slightly to allow the pressure to drop close to the next lowest calibration point ensuring that the pressure does not fall below the calibration point. Fully tighten the release valve (clockwise).
- (d) Wind the volume control knob anti-clockwise until calibration pressure is reached and record readings.
- (e) Wind the volume control knob fully clockwise (to ensure that the pressure release valve can be tightened satisfactorily).
- (f) Repeat paragraphs 3.2(c) to 3.2(e) for remaining calibration positions.
- (g) When test completed unscrew the pressure release valve before removing either instrument to ensure the system is not pressurised.

#### **4. SPECIFICATION**

---

Output Pressure	0 to 25bar (adjustable)
Output Vacuum	0 to -0.8bar/0 to -24inHg
Materials	Bright nickel plated brass, clear anodised aluminium
Adjustment	Fine volumetric pressure/vacuum adjuster
Dimensions	220mm (L) x 105mm (W) x 63mm (D)
Weight	650 grams







Comark  
52 Hurricane Way  
Norwich, Norfolk, NR6 6JB England  
Tel: 01603 (+44 1603) 256647  
Fax: 01603 (+44 1603) 256644  
E-mail: [service@comarkltd.com](mailto:service@comarkltd.com)

Website: [www.comarkltd.com](http://www.comarkltd.com)

Comark Instruments  
PO Box 9090, Everett  
WA 98206, USA  
Tel: (503) 643 5204  
Fax: (503) 644 5859  
Email: [sales@comarkUSA.com](mailto:sales@comarkUSA.com)

Website: [www.comarkUSA.com](http://www.comarkUSA.com)